



Table of Contents:

1. [Quick Installation Instructions](#)
2. [Required Tools](#)
3. [Supplied Parts](#)
4. [Step by Step Instructions](#)
5. [Leveling Instructions](#)

Spring Color Key (1" and 2")

Blue – 30 lb
Green - 60 lb
Red – 120 lb
Black – 200 lb

1. Quick Installation Instructions

- a) Check to ensure curb is level;
- b) Un-band isolation rails. Check to ensure A/B/C/D rail orientation matches the unit and curb orientation;
- c) Apply foam rubber to curb;
- d) Set isolation rails on curb;
- e) Install Tek screws, (2) at each corner;
- f) Drill thru curb into the wood nailer;
- g) Use bolts, washers and nuts to attach isolation rails to curb;
- h) Install (4) corner seals;
- i) Set unit on isolation rails, ensure unit is level;
- j) Remove/install additional supplied springs as needed.

2. Required Tools:

- Hand drill with 1/2" drill bit
- 9/16" open end wrench
- 9/16" socket wrench
- 3/8" socket wrench
- Scissors
- Razor blade
- Level

3. Supplied Parts:

- Rail assemblies
- 3/8" by 2 1/4" curb attachment bolts with washer and nut
- Corner bracket
- #14 by 1" Tek screw
- Neoprene foam tape
- Seal material
- Additional springs



4. Step by Step Instructions:

1. Read the entire installation instructions before assembling the VIBrail-VIR.
2. Install the roof curb in its designed location and roof up to the nailer.

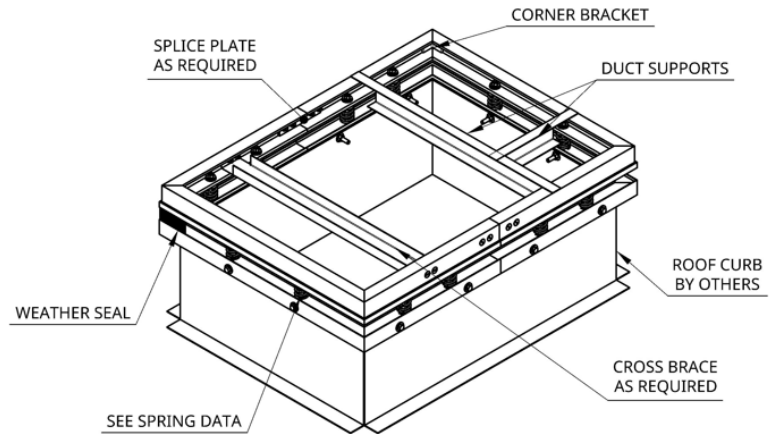
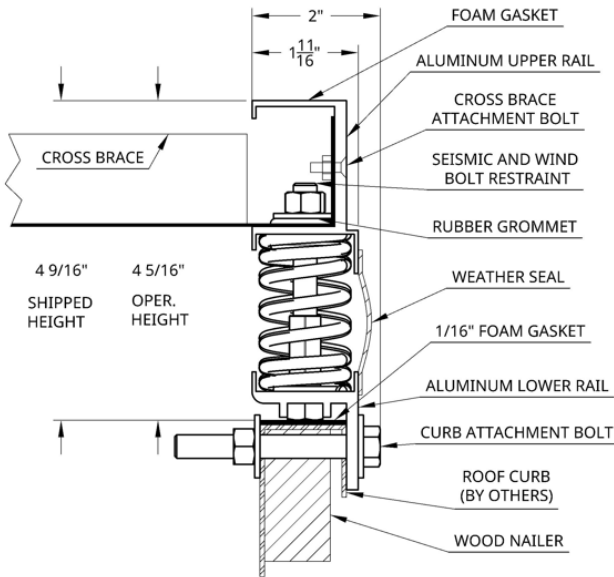

3. Make sure that all four sides of the sheet metal roof curb are level before assembling the VIBrail-VIR to the roof curb.
4. Along the top surface of the curb where the VIBrail-VIR will be sitting, place the supplied 1/16" thick by 1" wide neoprene foam tape. This tape is used to ensure a good seal between the curb and the isolation rail.
5. Place each rail one at a time in its designed location (look at submittal for orientation to supply duct, return duct or condenser end), line up the VIBrail-VIR with the top of the curb, and drill the mounting hole locations as shown below with a 1/2" drill bit. Repeat this for all four sides.
6. Rails will be marked A, B, C and D as shown on submittal drawing. Attach rails A and C using the 3/8" curb attachment bolts supplied (do NOT fully tighten bolts).
7. Attach rails B and D to the roof curb using the 3/8" mounting bolts (do NOT fully tighten bolts).
8. Attach the corner brackets already installed to rails B and D to rails A and C using the #14 by 1" Tek screws.

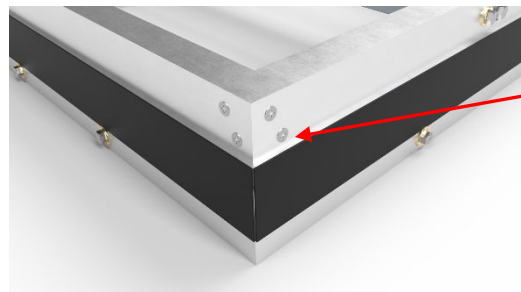

#14 Tek Screw

9. Now tighten all the 3/8" curb attachment bolts and nuts.
10. Installing flex connector, duct supports, and cross supports if required for your unit.
 - a. Refer to the unit manufacturers drawing for exact location of the supports.
 - b. If the unit manufacturer requires that the duct supports are dropped below the top of the isolation rail, then the duct support attachment flange will need to be bent in the field to the manufacturers specified drop. See drawing below.

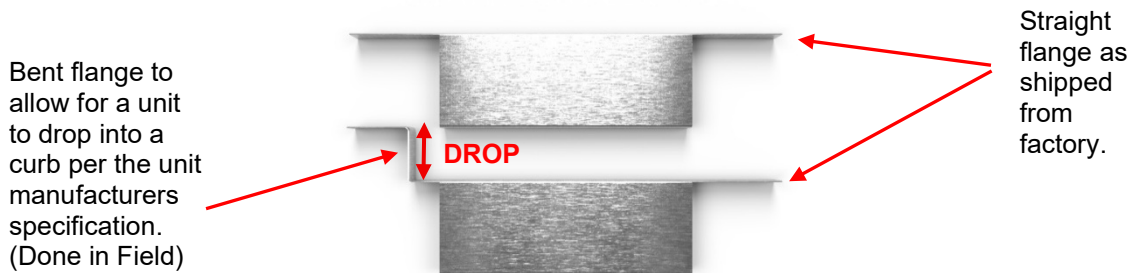

- c. Once the supports have been placed correctly on the top rail of the VIBrail-VIR assembly use a flexible material such as canvas or rubber (provided by others) sheet to connect the flex support to the mating duct work.

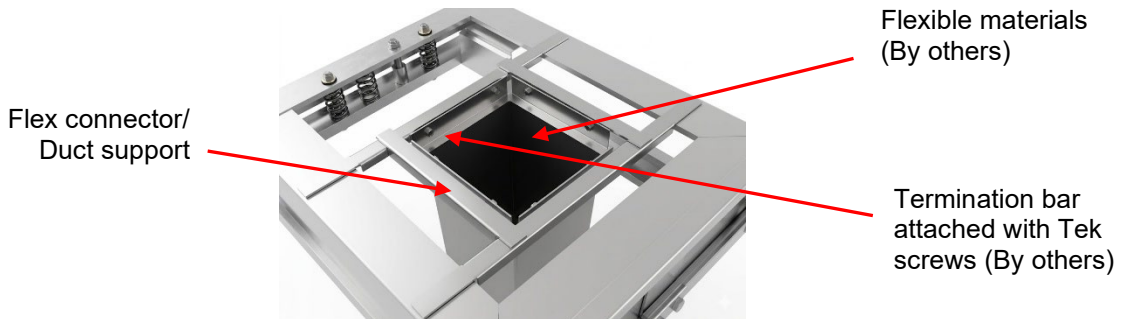

- d. If a cross support is required, attach the cross support using the provided hardware. The cross-support location is not specified but should be mounted somewhere relatively towards the center, or evenly spaced if there are more than one, without interfering with the duct supports or unit.

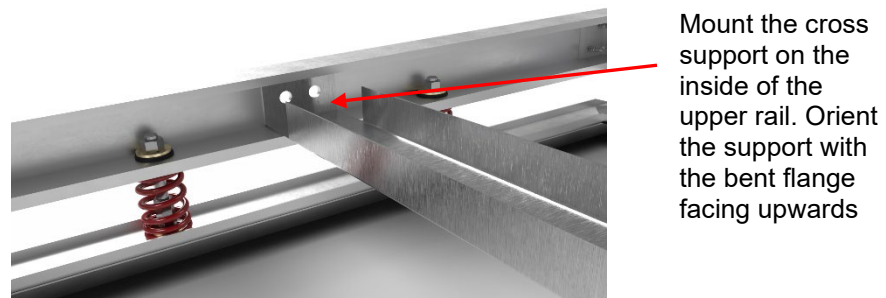

11. If the curb is designed to act as a plenum, please install the flex connector as shown in the drawing below.

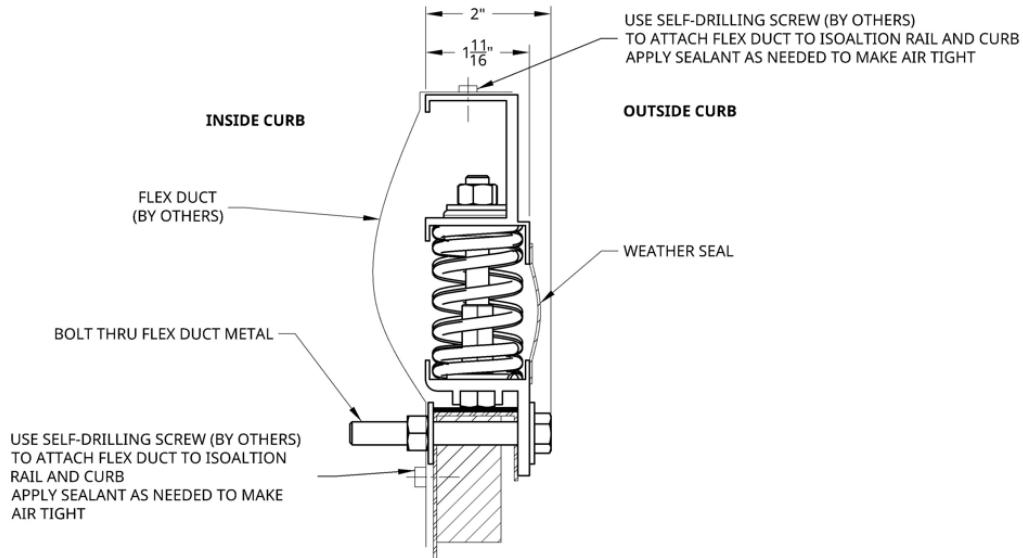

12. For each corner use the 4" wide seal material to completely cover the corners as shown below. Extra weather seal pieces are sent with the VIR and can be used seal any gaps or tares in the weather seal.

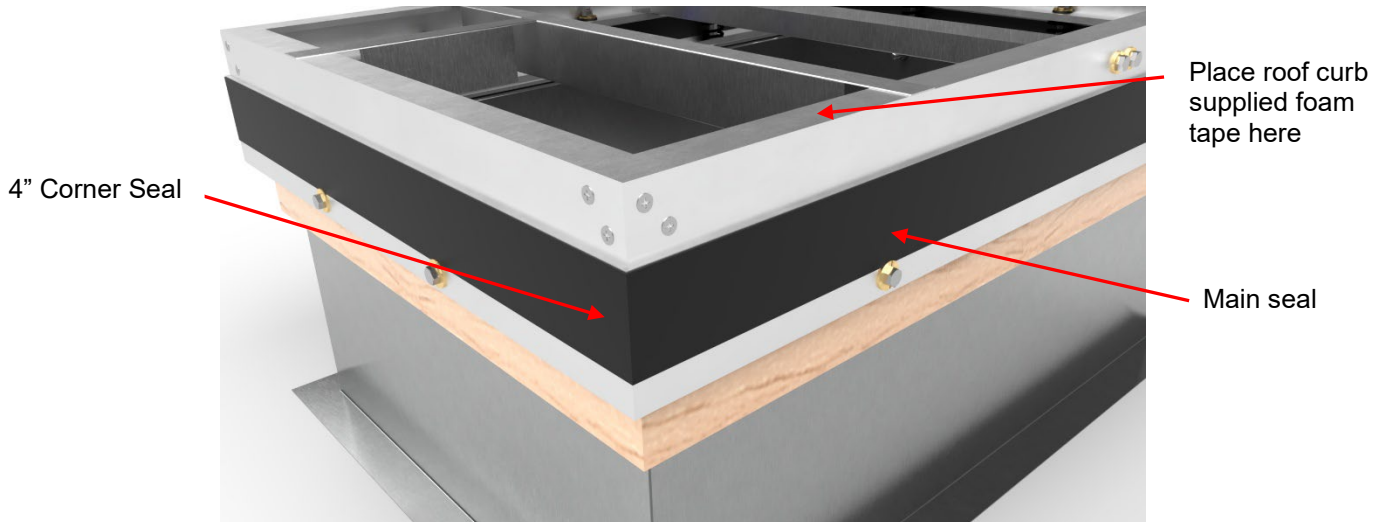

13. Place the thicker neoprene foam tape supplied with the roof curb on the top surface of the VIBrail-VIR to ensure a good seal between the unit and the isolation rail.

14. If the roof curb includes a drain pan section, rail D may need to be notched. Cut out a section of the lower rail to allow rail D to fit within the drain pan section. See the picture below.



15. Placing the unit on the VIBrail-VIR:
- Check to ensure the top of the VIBrail-VIR is level.
 - Double check that everything is installed per the installation instructions and the submittal data.
 - Check if there is any gasket material on the unit where it contacts the VIR. If there is, this material will need to be removed for a proper installation.
 - Position the air handling unit above the VIBrail-VIR before lowering the unit. Ensure it is level. Lower the unit very slowly.
 - Once the unit is resting completely on the VIBrail-VIR, check to ensure the unit is level before detaching it from the crane.
 - Attach the unit to the VIBrail-VIR using the unit manufactures specifications.
16. Trouble shooting installation.
- If the unit is not sitting level, mark where the unit is sitting the lowest.
 - Have the crane lift the unit back up.
 - Install the additional springs in the location that was sitting the lowest.
 - Place the unit back on the VIBrail-VIR and ensure it is sitting level.



5. Leveling Instructions:

- If the unit can be lifted off the isolation rails, then a spring can be inserted from the inside of the isolation rail as described in section 15 of the installation instructions attached. (Also need to follow item 1 below for spring placement).
- If the unit cannot be lifted off the isolation rails, then the springs will need to be inserted from the outside.
 1. This will require the removal of small section of the seal where the additional springs will be inserted.
 - a) Insert a green spring evenly along a side of the unit that is low.
 - b) If after adding green springs the unit is still sitting low, then remove springs from opposite side of unit until level.
 2. In order to insert the springs, use a jack or pry bar to slightly lift the unit to allow the springs to be inserted.
 3. Once all of the springs are in place, use the newly supplied seal material to replace the areas where the seal was cut.

If there are questions regarding these instructions, contact us at (800)-735-9645.

For more information regarding the VIBrail-VIR system or any of the VIB-ISO products please visit us on the web at www.VIBISO.com.