



Product Data Sheet: VIBmount-SS

Applications

- Floor or roof mount
- Equipment with fluctuating operating weight
- High capacity

Features

- Channel housing with steel coil spring
- Integrated seismic and wind restraints
- Elastomeric isolation pad
- Easy installation
- 1" or 2" deflection

VIBmount-SS Isolator

The VIBmount-SS isolator VIB-ISO's high capacity roof curb or floor-mount isolator ideal for equipment with fluctuating operating weights. Designed to integrate with any roof curb or floor-mounted piece of equipment, the VIBmount-SS isolator will aid to reduce the vibration from large mechanical and electrical equipment to the building structure. The Assembled VIBmount-SS Isolator VIBmount-SS has integrated lateral and vertical restraints in order to account for seismic and wind loads. Additionally, the channel design of the VIBmount-SS housing accounts for additional seismic load capacity.

VIB-ISO will engineer each VIBmount-SS isolator to match your specified unit and meet any additional customer requirements. The VIBmount-SS isolator is available in either 1" or 2" deflection and is shipped fully assembled with the springs and restraints installed at VIB-ISO in order to reduce onsite labor requirements. The springs are made of structural steel and sit on an elastomeric mount. The housing is made entirely of structural steel. On site, the VIBmount-SS design allows for quick assembly requiring only basic tools for installation.

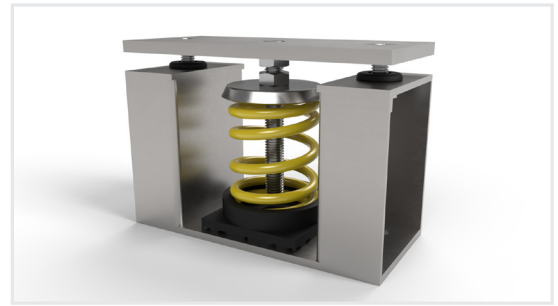

Assembled VIBmount-SS Isolator

VIBmount-SS Attributes

The VIBmount-SS isolator is designed to reduce the vibration from large-scale, roof curb or floor-mounted mechanical and electrical equipment with fluctuating operating weights when additional seismic and wind restraints are required. For buildings in which the end user demands critically quiet areas, vibration isolation control of large mechanical and electrical equipment is a necessity.

The VIBmount-SS isolator uses integrated seismic restraints to allow for the equipment to be attached to the building while also allowing for flexing during a seismic event. This integrated design meets all applicable IBC (International Building Code) and ASCE (American Society of Civil Engineers) codes and requirements. The VIBmount-SS isolator is recommended for isolating equipment with large fluctuating operating weights that also demand high seismic capacity.

SOURCED IN USA



VIB-ISO

P.O. Box 1022
Wooster, OH 44691
1-800-735-9645



Product Data Sheet: VIBmount-SS

VIBmount-SS Specifications

1. Vertically and laterally restrained spring isolator with constant free and operating height.
2. Elastomeric pad for high-frequency noise reduction.
3. Steel coil and housing assembly, painted.
4. Minimum coil overload of 50%.
5. Housing may be used for blocking during equipment installation.
6. Meets IBC and ASCE code specifications
7. 100% Made in the U.S.A.

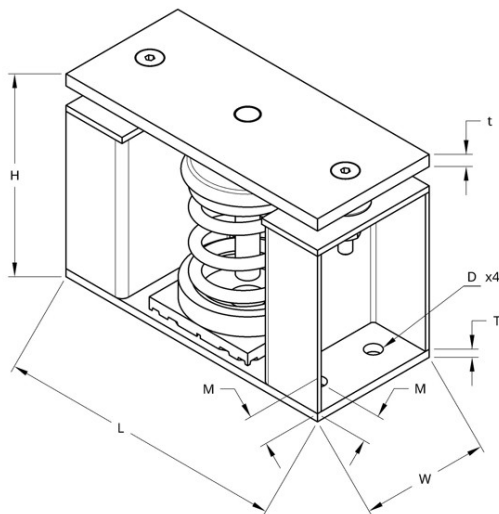

ISOLATOR DIMENSIONS (INCHES)							
TYPE	H	L	W	T	t	D	M
VIBmount-SS-1	6.25	9.00	4.00	0.25	0.38	0.50	1.00
VIBmount-SS-2	8.00	9.00	4.00	0.25	0.38	0.50	1.00

SPRING DATA (INCHES AND POUNDS)					
HOUSING	TYPE	RATING	COLOR	FREE HT.	O.D.
SS	1	60	GREEN	2.50	1.50
SS	1	120	BLACK	3.19	1.75
SS	1	250	BLUE	4.20	3.00
SS	1	370	BLUE/BLACK	4.20	3.00
SS	1	450	YELLOW	4.20	3.00
SS	1	570	YELLOW/BLACK	4.20	3.00
SS	1	800	BROWN	4.20	3.00
SS	1	1000	RED	4.20	3.00
SS	1	1200	GRAY	4.20	3.00
SS	1	1320	GRAY/BLACK	4.20	3.00
SS	1	1700	BLACK	4.20	3.00
SS	1	1820	BLACK/BLACK	4.20	3.00
SS	2	100	WHITE	6.00	3.50
SS	2	250	YELLOW	6.00	3.50
SS	2	375	YELLOW/BLUE	6.00	3.50
SS	2	500	GREEN	6.00	3.50
SS	2	625	GREEN/BLUE	6.00	3.50
SS	2	750	BROWN	6.00	3.50
SS	2	875	BROWN/BLUE	6.00	3.50
SS	2	995	RED	6.00	3.50
SS	2	1120	RED/BLUE	6.00	3.50
SS	2	1395	RED/GRAY	6.00	3.50
SS	2	1600	BLACK	6.00	3.50
SS	2	1725	BLACK/BLUE	6.00	3.50
SS	2	2000	BLACK/GRAY	6.00	3.50

For more information regarding the VIBmount-SS Isolator, please visit us at www.vibiso.com.