

VIMH-S Overview

Applications

- Floor or roof mount
- Economical design
- High capacity

Features

- Integrated seismic and wind restraints
- Steel coil and housing
- Easy installation

Specifications

- 1" or 2" deflection
- Meets IBC and ASCE code specifications
- 50% coil overload

VIB-ISO

PO Box 1022

Wooster, OH 44691

1-800-735-9645

VIMH-S Isolator

The VIMH-S isolator is VIB-ISO's high capacity, economical roof curb or floor-mount isolator. Designed to integrate with any roof curb or floor-mounted piece of equipment, the VIMH-S isolator will aid to reduce the vibration from large mechanical and electrical equipment to the building structure. Additionally, the VIMH-S has integrated lateral and vertical restraints in order to account for seismic and wind loads.

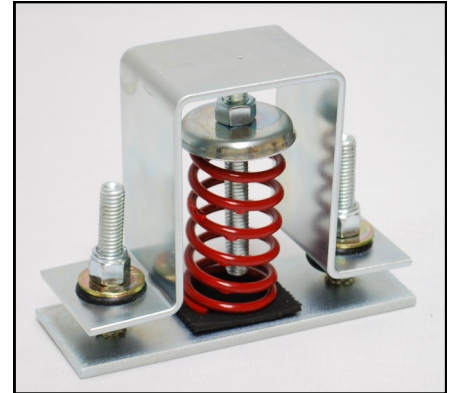

Assembled VIMH-S Isolator

VIB-ISO will engineer each VIMH-S isolator to match your specified unit and meet any additional customer

requirements. The VIMH-S isolator is available in either 1" or 2" deflection and is shipped fully assembled with the springs and restraints installed at VIB-ISO in order to reduce onsite labor requirements. The springs are made of structural steel and sit on an elastomeric mount. The housing is made entirely of structural steel. On site, the VIMH-S design allows for quick assembly requiring only basic tools for installation.

VIMH-S Attributes

The VIMH-S isolator is designed to reduce the vibration from large-scale, roof or floor-mounted mechanical and electrical equipment when additional seismic and wind restraints are required. For buildings in which the end user demands critically quiet areas, vibration isolation control of large mechanical and electrical equipment is a necessity. The VIMH-S isolator uses a coil spring as the resilient media to absorb the vast majority of vibration energy emanating from any large piece of equipment.

The VIMH-S isolator uses integrated seismic restraints to allow for the equipment to be attached to the building while also allowing for flexing during a seismic event. This integrated design meets all applicable IBC (International Building Code) and ASCE (American Society of Civil Engineers) codes and requirements. The VIMH-S isolator is recommended for isolating equipment with large loads and vibration concerns including, but not limited to, boilers, chillers, pumps, condensers, and air-conditioning units.

VIB-ISO Floor Isolator Selector

by increasing structural load (seismic) capability

VIMF	VIMM	VIMH	VIMH-S	VIMS	VIMS-S
------	------	------	--------	------	--------

VIMH-S Specifications

1. Vertically and laterally restrained spring isolator with constant free and operating height.
2. Elastomeric pad for high frequency noise reduction.
3. Steel soil and housing assembly, painted.
4. Minimum coil overload of 50%.
5. Housing may be used for blocking during equipment installation.
6. Available in 1 inch or 2 inch deflection.
7. 100% Made in the U.S.A.

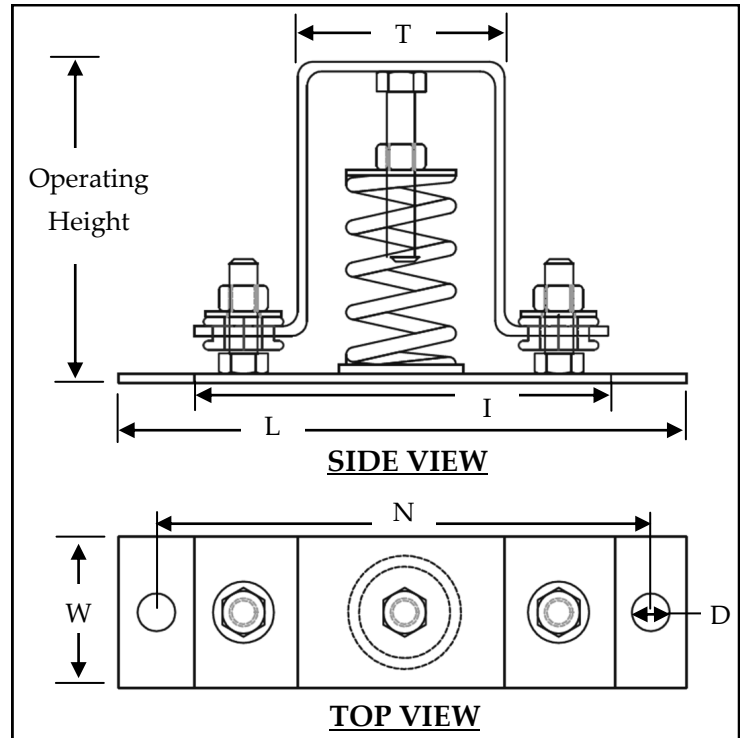

VIMH-S Types

TYPE	Height	L	I	T	N	W	D
VIMH	5-1/2	10-1/2	N/A	4	9	3-1/2	1/2

SPRING DATA (INCHES)					
HOUSING	TYPE	RATING	COLOR	FREE HT.	O.D.
VIMH-S	1	120	GRAY	3.2	1.75
VIMH-S	1	250	GREEN	4.2	3
VIMH-S	1	370	GREEN/GRAY	4.2	3
VIMH-S	1	450	BLUE	4.2	3
VIMH-S	1	620	BLUE/GRAY	4.2	3
VIMH-S	1	800	BLACK	4.2	3
VIMH-S	1	920	BLACK/GRAY	4.2	3
VIMH-S	1	1100	BLACK/YELLOW	4.2	3
VIMH-S	1	1300	BLACK/YELLOW	4.2	3
VIMH-S	1	1600	BLACK/GRAY	4.2	3
VIMH-S	2	100	YELLOW	6	3.5
VIMH-S	2	250	GREEN	6	3.5
VIMH-S	2	500	BLUE	6	3.5
VIMH-S	2	700	RED	6	3.5
VIMH-S	2	950	GRAY	6	3.5
VIMH-S	2	1200	GREEN	6	3.5

For more information regarding the VIMH-S isolator or any of the VIB-ISO products, please visit us on the web at www.vibiso.com.